

C.13 INTERMEDIATE FLOORS

Joists for intermediate floors are generally installed with joist hangers attached to a ledger board (“rim joist”), anchored to the PolySteel wall. There are a variety of methods available to accomplish the secure attachment of a rim joist, however, the following systems are recommended in the order of preference and efficiency.

C.13.1 SIMPSON ICF LEDGER CONNECTION SYSTEM.

Simpson Strong-Tie has developed a fully engineered system for the attachment of wood or steel ledgers that is simple by design, easy to install, and provides maximum flexibility. A patented, L-shaped, galvanized steel bracket (ICFLC) is inserted into the PolySteel wall at the appropriate location, where it is cast in concrete to provide a secure anchor for the direct attachment of a steel rim joist, or the Simpson wood ledger hanger (ICFLC-W), or engineered hanger (ICFLC-W). Follow the steps and illustrations below for proper installation.

Figure 3.14 SIMPSON ICF WOOD OR LVL LEDGER CONNECTOR SYSTEM

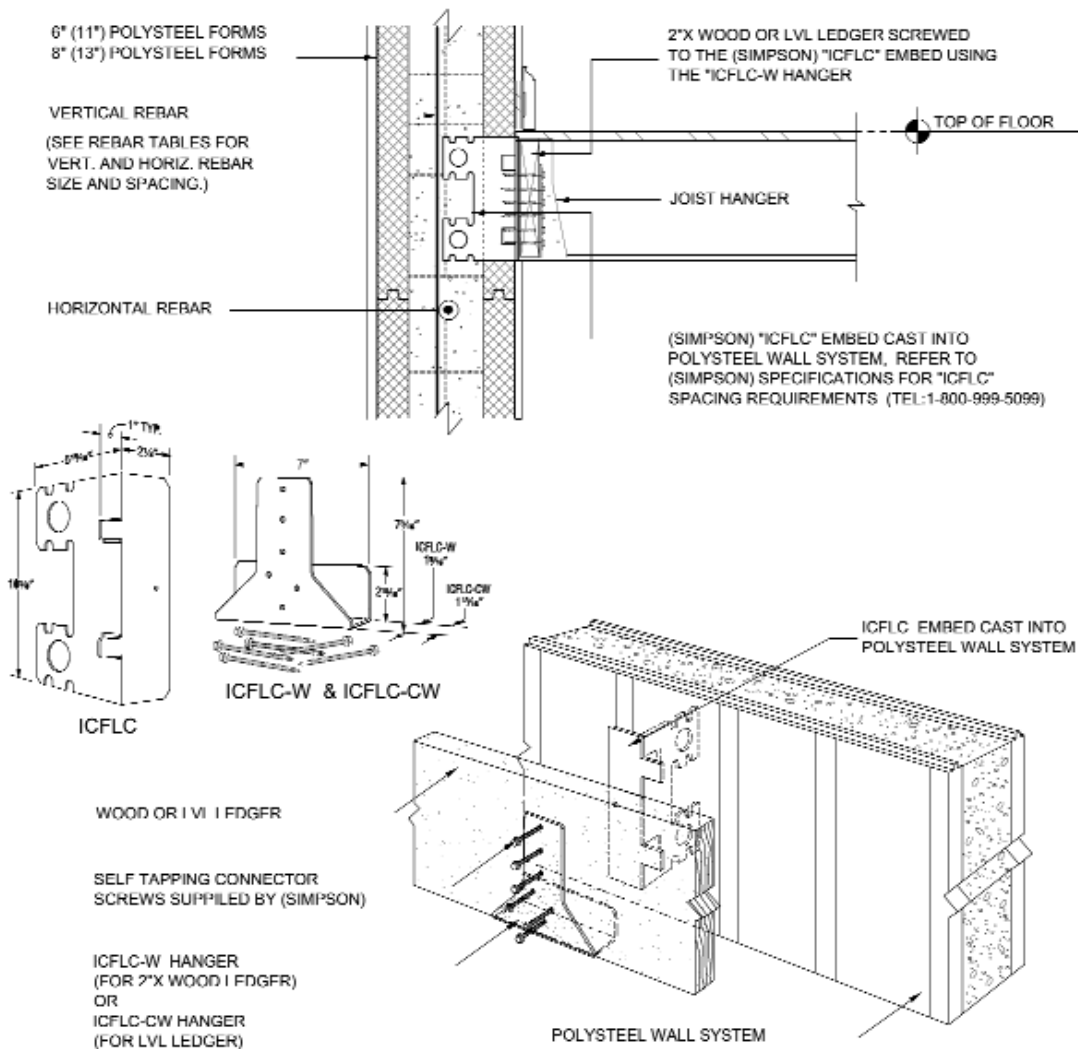

C.13 INTERMEDIATE FLOORS

C.13.1 SIMPSON ICF LEDGER CONNECTION SYSTEM (continued)

Figure 3.15 SIMPSON ICF STEEL LEDGER CONNECTOR SYSTEM

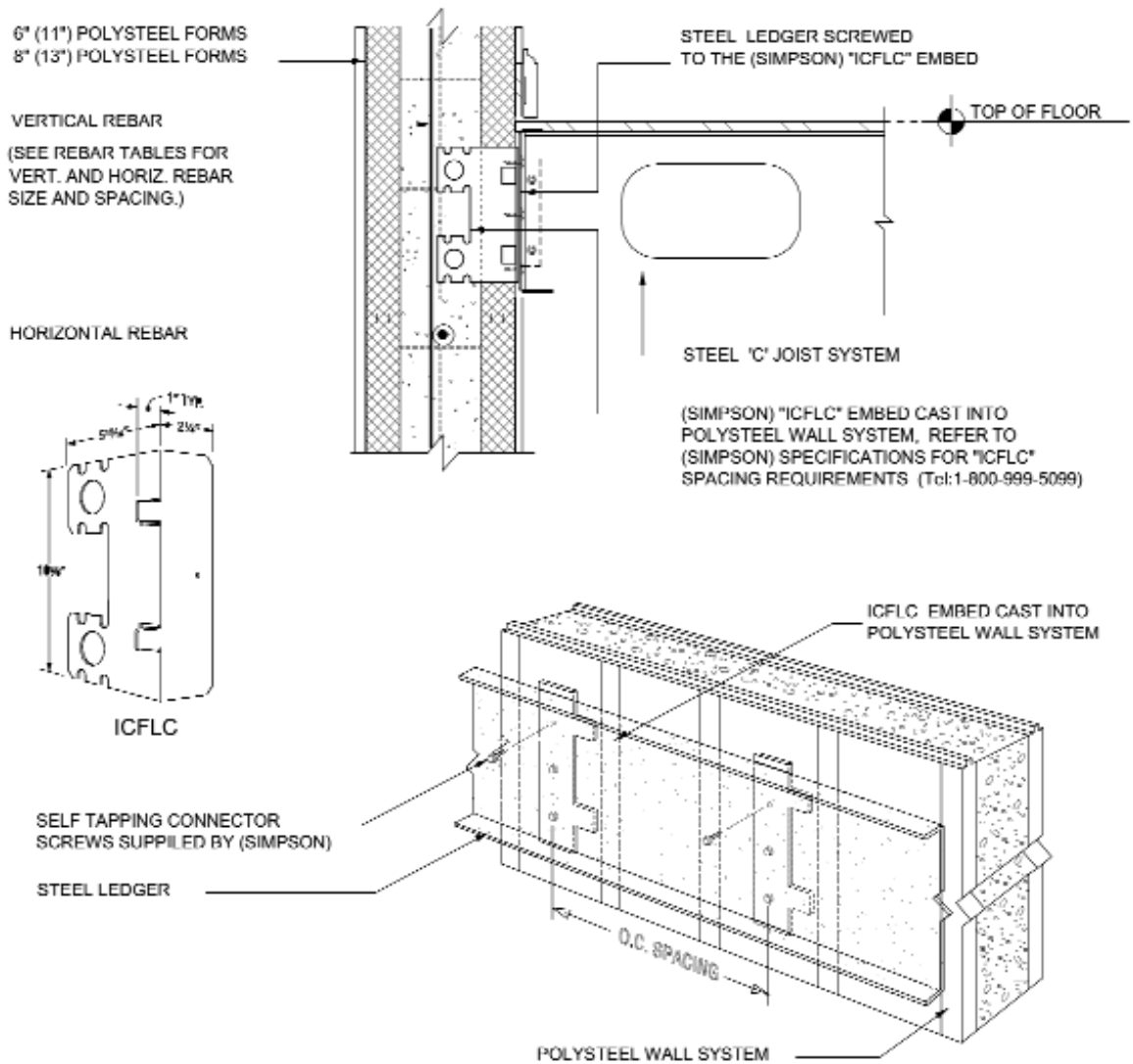

C.13 INTERMEDIATE FLOORS.

C.13.1 SIMPSON ICF LEDGER CONNECTION SYSTEM (continued)

- ✓ Consult your PolySteel Dealer or Simpson to determine the proper spacing of the ICFLC brackets to be installed, based on the floor span, seismic conditions, load requirements, and type of framing material to be used for the joists.
- ✓ Snap a chalk line for the bottom of the ledger and mark the required on-center spacing for the ICFLC brackets.
- ✓ Cut vertical slots at the marked location on the PolySteel wall to match the height of the bracket and so that the bottom of the face of the bracket is 1" below the chalk line.
- ✓ Insert a bracket at each cut. Use Foam2Foam to glue the back face of the bracket to the PolySteel wall, or, once all brackets are in place, you can secure a piece of lumber across the face of the entire line by screwing to the steel attachment studs in the PolySteel Forms.
- ✓ Based on the type of ledger to be installed (steel or wood) consult the Simpson catalog to determine the correct number and size of screws to be used to carry the required load.
- ✓ **Light Gauge Steel.** Position the steel track against the ICFLC brackets and in alignment with the chalk line and drive the required number of screws through the ledger and into the bracket. All screws should be spaced evenly and located at least 1/2" from the edge of the ICFLC. Screws must be Simpson-approved fasteners.
- ✓ **Wood Ledger.** Slip the ICFLC-W hanger underneath the wood ledger and attach 6 screws partially into the ledger. Position the ICFLC-W so that the bottom of the ledger is aligned with the chalk line and drive the screws through the ledger and into the ICFLC bracket. Screws must be Simpson-approved fasteners.



**SIMPSON
HANGER INSTALLATION**



**SIMPSON HANGER
STEEL FLOOR**



**SIMPSON HANGER
WOOD LEDGER**

C.13 INTERMEDIATE FLOORS

C.13.2 LEDGER BOARD.

You may attach a wood ledger directly to the PolySteel wall by removing foam at prescribed intervals to allow for the installation of anchor bolts to secure the ledger in place. Standard joist hangers may then be attached to the rim joist in accordance with the requirements of the floor system. The building code does not require that wood be protected from concrete unless the concrete is in contact with the soil. However, if required by the local building official, the wood should be protected wherever it comes into direct contact with concrete. Accordingly, ledger boards should be covered with roofing felt, or another protective material, or should be otherwise pre-treated.

Figure 3.16 TYPICAL LEDGER BOARD CONNECTION

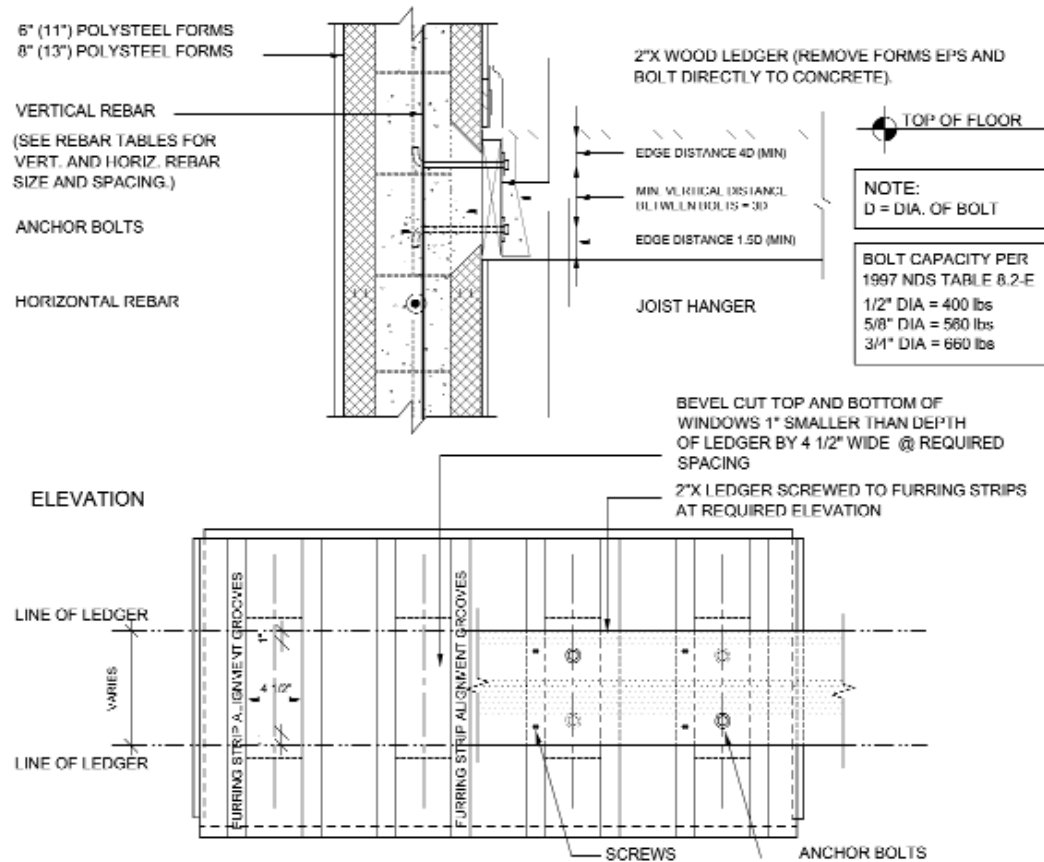

ANCHOR BOLT REQUIREMENTS (LL = 40 PSF & DL = 15 PSF)				
CLEAR SPAN	R(l)	1/2" DIA. BOLT	5/8" DIA. BOLT	3/4" DIA. BOLT
22'	605 plf	2 @ 12" o.c.	2 @ 12" o.c.	2 @ 24" o.c.
20'	550 plf	2 @ 12" o.c.	2 @ 24" o.c.	2 @ 24" o.c.
18'	495 plf	2 @ 12" o.c.	2 @ 24" o.c.	2 @ 24" o.c.
16'	440 plf	2 @ 12" o.c.	2 @ 24" o.c.	2 @ 24" o.c.
14'	385 plf	2 @ 24" o.c.	2 @ 24" o.c.	2 @ 36" o.c.
12'	330 plf	2 @ 24" o.c.	2 @ 36" o.c.	2 @ 48" o.c.
10'	275 plf	2 @ 24" o.c.	2 @ 36" o.c.	2 @ 48" o.c.
*RIM JOIST	55 plf	2 @ 72" o.c.	2 @ 72" o.c.	2 @ 72" o.c.

NOTES: R(l) = REACTION (TOTAL LOAD) pounds per lineal foot
n/a = NOT ALLOWED
LL = DESIGN LIVE LOAD (pounds per square foot)

DL = DESIGN DEAD LOAD (pounds per square foot)
* = RIM JOIST @ NON-LOAD BEARING WALL (minimum bolt requirements)

C.13 INTERMEDIATE FLOORS

C.13.2 LEDGER BOARD (continued)

- ✓ Snap chalk lines around the perimeter of the wall to mark the top and bottom of the rim joist to be used.
- ✓ Consult the table in [Figure 3.16](#) to determine the proper intervals for installing anchor bolts (eg., every 12", 24", 36" etc.). At each prescribed location, starting 1" below the top of the ledger, cut a "window" into the foam that is 4-1/2" wide and extends to 1" above the bottom of the ledger (e.g., for a 2x10 ledger, the hole would be 4"x 8").
- ✓ Drill holes in the ledger board to allow for the installation of J-shaped anchor bolts. Holes must be located at least 4 times the diameter of the bolt from the edge of the ledger (e.g., 2" for a 1/2" anchor bolt).
- ✓ Pre-install the anchor bolts and screw the nuts on to set the bolt at the proper depth.
- ✓ Attach the ledger board to the wall at the chalk lines by screwing it to the PolySteel attachment studs with two screws every 12".
- ✓ Once the concrete has cured, you may install joist hangers and tighten the anchor bolts in place to properly secure the ledger. You should consult your PolySteel representative for any alternative floor connection systems, such as anchor tunnels and/or pre-cast ICF joist hangers, to determine if they are appropriate for your project.